



CASE
CONSTRUCTION

SV-SERIES STAGE V BACKHOE LOADERS



580SV | 590SV | 695SV

ACROSS HISTORY



1842

CASE is founded.

1869

The first CASE portable steam engine - road construction is born!

1957

CASE produces the first ever factory integrated backhoe loader.

1959

CASE TLB 420 is the first diesel powered model.

1964

CASE is the first manufacturer to develop an extendable dipper, the patented CASE Extindahoe.

1999

CASE is the first company to offer a powershift transmission on a backhoe loader.

2000

CASE is the first company to offer a backhoe integrated quick coupler.

2001

CASE M series backhoe is listed in "Construction Equipment" magazine among the top 100 products.

2005

CASE produces its 500,000th backhoe.

2012

CASE achieves Tier 4 emissions standards while delivering best-in-class breakout force and lift capacity.

2016

CASE backhoe offering is enlarged introducing "In-Line cylinders" backhoe and "Straight-Loader arm" options.

2017

CASE introduces a Tier 4 final fully customizable backhoe.

2019

60th year milestone. Future in the making.

2020

CASE presents in North America the industry's first Fully Electric Backhoe Loader (model 580 EV).

2021

CASE introduces a Stage V TLB with a brand-new cab, bringing operator comfort to the next level.

SV-SERIES BACKHOE LOADERS

THE KINGS

CASE BACKHOE LOADERS

The original, ready for anything

Since introducing the first ever integrated backhoe loader in 1957, CASE has always been a front runner in the tractor loader backhoe industry.

We have built a strong heritage of industry firsts, on best-in-class performances and components, supremely reliable and well-proven technology, and productivity-boosting solutions.

It's no surprise, then, that faced with the challenge of meeting Stage V emissions regulations, we did it "the CASE way".

- + We accepted no compromise on performances: the new 3.6-litre FPT Stage V engine maintains the same best-in-class power and torque density of its Stage IV predecessor.
- + We designed with FPT an After-Treatment System specifically for backhoe loader applications - because we know them inside out!!

And we did not limit our efforts to power and performance:
with the SV-Series we have taken operator comfort to the next level!

- + The new cab is wider to provide more room for the operator.
- + The new cab is more ergonomic
- + The new cab has a completely new interior and exterior style

Now it's time to enhance our Customer's experience with the NEW SV-SERIES BACKHOE LOADERS.



SV-SERIES BACKHOE LOADERS

OPERATOR COMFORT TO THE NEXT LEVEL



NEW WIDER CAB

FEATURES	BENEFITS
+ NEW Restyled interior and exterior	Greater operator comfort and improved ergonomics
+ NEW Front and LH consoles design	Superior cab accessibility
+ NEW Superior roominess for the operator	Excellent knee and feet clearance when rotating the seat from loader to backhoe position
+ NEW Noise level reduced to 74dB	A quiet place to work!
+ NEW layout of switches and controls	Easy reachability in both loader and backhoe position
+ NEW Wider Pilot Control towers adjustability	Better ergonomics
+ NEW Best in class internal storage capacity: 4 times more than ST Series cab, including: 2 Lockable compartments, 2 Bottle/Cup holder, Cooling Box and 4 open trays	A place to store every item and to keep your lunch and drinks always fresh
+ NEW Excellent 360° Visibility	More productivity and safety on the job site and in the street
+ King class seat: the super deluxe air suspension option offers premium features	Height, lumbar and armrests full adjustability, and heating
+ Powerful Air Conditioning and fully openable windows	Excellent cab ventilation



CAB FEATURES FOR A MORE PLEASANT AND SAFE WORKING DAY AND DRIVE

FEATURES	BENEFITS
+ NEW Bluetooth radio option	Located on right hand pillar, easy reachability in any position
+ NEW Speedometer option	Located on front console, more safety when driving
+ NEW 2 speed wiper	Better visibility when driving in rainy/snowy conditions
+ NEW F-N-R switch on loader handle	Easy transmission direction change in loading applications
+ NEW Roller switch on pilot joysticks	Quick and precise dipper extension
+ NEW Cell-phone holder	Located on right hand pillar, easy reachability in any position
+ NEW 12V and USB ports	Conveniently located on the right-hand console
+ NEW Anti-Theft system	Peace of mind
+ 10 LED working lights option	Your work in dark conditions will be as bright as ever

SV-SERIES BACKHOE LOADERS

SUSTAINABLE PERFORMANCE



AS POWERFUL AS EVER!

Notwithstanding the stringent Stage V emission requirements, we accepted no compromise on performance!

The **NEW** 3.6-litre **FPT Stage V engine** maintains the same **best-in-class power and torque density** of its Stage IV predecessor.

F36

3.6 lt 4 cylinders

16v, Common Rail Injection

Compact Hi-eSCR2



LOW EMISSIONS

- + The **NEW** 3.6-litre FPT engine dramatically reduces emissions, meeting Stage V stringent requirements with **no fuel and urea consumption deterioration vs Stage IV**,
- + **NEW Compact Hi-eSCR2 After Treatment system** designed with FPT specifically for Backhoe loader applications
- + **NEW ECO mode** is standard on all units and delivers **10% fuel consumption saving**
- + Environmentally friendly!!
 - **NEW Auto Engine Shutdown:**
Automatic engine switch off when the machine is inactive for more than 3 minutes
 - **NEW Auto Idle:** Automatic reduction of engine speed when the machine is inactive for more than 5 seconds
 - Fully HVO diesel compatible
 - Biodegradable lubricants option available



SAFE, EASY AND LOW-COST MAINTENANCE

- + **One side engine serviceability** layout and all fuses and relays comfortably located in the cab for easy and fast maintenance operations
- + **Maintenance free After Treatment System** for reduced operating costs and maximized vehicle uptime
- + Minimum operating costs with **500 hours oil change interval and efficient low-rate EGR combustion (<10%)**
- + **Auto Engine protection shutdown** feature turns off automatically the engine when the most critical engine and transmission parameters are detected to be outside proper working conditions. Another solution that minimizes the costs of extraordinary maintenance!

SV-SERIES BACKHOE LOADERS

VERSATILITY FOR HIGH PRODUCTIVITY



CASE DNA BACKHOE

- + **Exclusive outer extendahoe:** all components in contact with the soil are **protected** against impact and material accumulation
- + The curved main boom provides greater digging ability and makes it easier to load a truck
- + **Low profile for easy transport**
- + **Patented CASE DNA integrated hydraulic quick coupler** allows changing over the backhoe attachments from the cab with a simple switch whilst preserving backhoe performance just as if the attachments were direct fit.
- + Gripper teeth for **excellent material retention**
- + **Swing Dampening** for precise backhoe operations and improved operator comfort.

TOOL CARRIER LOADER ARM

- + **NEW Hydraulic quick coupler** for easy and quick attachments swap.
- + The loader's **excellent lift capacity combined with the mechanical parallel lifting** delivers greater productivity.





IN-LINE CYLINDER BACKHOE

- + **Great visibility** thanks to the narrower frame
- + High stress resistance thanks to the balanced effort distribution along the boom
- + **NEW Hydraulic quick coupler** for easy and quick attachments swap
- + **Swing Dampening** for precise backhoe operations and improved operator comfort

STRAIGHT LOADER ARM

- + **Top loading reach and lifting capacity:** the perfect solution for professionals requiring a particularly high tipping point.
- + The simple structure ensures **great visibility** and low maintenance costs
- + **Anti-tipping function** keeps the bucket in the correct position while lifting the load, with no risk of material spillage



MAIN REASONS TO CHOOSE THE NEW SV-SERIES

PRODUCTIVITY / PERFORMANCE

- + **Best in class engine power and torque**
- + **Top of the industry Loader arm and Backhoe Lifting, Loading and Digging performances**
- + **NEW** F-N-R switch on loader handle for **easy transmission direction change** in loading applications
- + **NEW** Roller switch on pilot joysticks for **quick and precise dipper extension**
- + Protected Backhoe operations with the **powerful Case DNA backhoe**
- + **Patented CASE DNA integrated hydraulic quick coupler**
- + **Hydraulic side shift** enables easy and quick backhoe repositioning in all working conditions, while also preserving all types of soil.

COMFORT

- + **NEW** Superior in-cab **roominess** for the operator
- + **NEW** **Bluetooth radio and speedometer** options for a more pleasant and safe working day and drive
- + **NEW** **Excellent visibility** for productive and safe loader and backhoe operations.
- + **NEW** **Top of the industry in-cab storage compartment capacity**
- + Fully openable windscreens for **excellent cab ventilation**
- + **10 LED working lights:** bright work even in the darkest conditions.



TOTAL COST OF OWNERSHIP

- + **NEW** The 3.6-litre **FPT Stage V engine** dramatically reduces emissions with **same fuel consumption as Stage IV engine** and ensures **low maintenance costs**
- + **NEW ECO mode** is standard on all units and provides 10% fuel consumption saving
- + **NEW Auto engine shutdown and Auto idle:** you can **save fuel** and be **environmentally friendly** at the same time
- + **Variable Volume Pump** reduces consumption, by providing oil only when needed
- + Coming from a backhoe loader industry leader means not only a rich heritage, but also **proven technology and best-in-class suppliers.** This translates into **high reliability, more uptime, more productivity, and lower maintenance costs.**

360° SERVICE SOLUTIONS

- + **CASE SiteWatch™** makes fleet management easy, helping improve your productivity and profitability
- + **NEW CASE SiteConnect** enables your dealer to be proactive in managing your machine, boosting its uptime
- + **NEW CASE Protect extended warranty** and **CASE Care planned maintenance** give you full peace of mind



SV-SERIES BACKHOE LOADERS

CASE SERVICE SOLUTIONS



CASE Service Solutions is a 360° service package that covers different dimensions of your experience with the CASE equipment to boost productivity and improve the machine's Uptime.

It includes our Connected Services offering: **CASE SiteWatch™**, a complete fleet management tool, helps you secure your fleet and provide valuable machine information to improve your productivity and profitability. **CASE SiteConnect** enables your dealer to be proactive in supporting your machine and boosting its uptime.

It also means full peace of mind thanks to **CASE Protect**, our extended warranty program, and **CASE Care**, the planned maintenance for CASE customers. We also offer **CASE Fluid Analysis** to prevent major failures, maximize your machine's reliability and extend its lifetime.

In other words, **CASE Service Solutions** will keep the equipment in top condition with maximum uptime, no unexpected costs and optimized profitability!

580SV – 590SV – 695SV

MAIN SPECIFICATIONS

SPECIFICATIONS	580SV		590SV		695SV
ENGINE					
Make and Model	FPT F5C - F5MGL413B		FPT F5C - F5MGL413A		
Injection system	High Pressure Common Rail				
Emissions level	Stage V				
# of cylinders	4				
Bore / Stroke	102 mm x 110 mm				
Displacement / Compression ratio	3.6 ltr / 17 to 1				
Engine rated Power (ISO 14396)	72 KW (97 hp) @ 2200 rpm		82 KW (110 hp) @ 2200 rpm		
Max Net Power	84 KW (112 hp) @2000 rpm		89 KW (119 hp) @1900 rpm		
Maximum torque (ISO 14396)	453 Nm @ 1400 rpm		460 Nm @ 1400 rpm		
Engine speeds	2200 rpm (rated speed at full load) / 900-1000 rpm (low speed at no load)				
TRANSMISSION					
Type	4WD				4WD - 4WS
Model	Powershuttle Carraro TLB1 PB 4WD	Powershift Carraro TLB2 MPB 4WD	Powershuttle Carraro TLB1 PB 4WD	Powershift Carraro TLB2 MPB 4WD	Powershift Carraro TLB2 4WS MPB
Forward travel speeds	6 - 10 - 21 - 40 (kph)				7 - 11 - 24 - 40 (kph)
Reverse travel speeds	7 - 12 - 26 - 47 (kph)				8 - 13 - 29 (kph)
FRONT AXLE					
Model	4WD Heavy duty			4WD with limited slip differential	
Oscillation	+/- 11°			+/- 8°	
REAR AXLE					
Model	Carraro 28.44FR with Differential lock		Carraro 28.50 with Differential lock		Carraro 26.43 with limited slip differential
BRAKES					
Service brakes	Hydraulic foot operated, 2 disc per side				Hydraulic foot operated, 3 disc per side
Parking brakes	Mechanically actuated				
TIRES					
Front	18"	20"	18"	20"	28"
Rear	26" or 28"	30"	26" or 28"	30"	28"
STEERING					
Type	Power Steering				
System pressure / Displacement	180 bar / 160 cc				
Turning radius 4WD (external radius)	With 18" tires: 4300 mm with brakes off 3600 mm with brakes on				With 28" tires: 8180 mm in 2WS mode with brakes off; 6820 mm in 2WS mode with brakes on; 4810 mm in 4WS mode with brakes off
HYDRAULIC SYSTEM					
Type	Load sensing closed center with twin gear pump	Load sensing closed center with variable volume pump	Load sensing closed center with variable volume pump	Load sensing closed center with variable volume pump	
Flow (@ 2200 rpm)	156 l/min	6 to 165 l/min	6 to 165 l/min	6 to 165 l/min	
Pressure	205 bar		205 bar	205 bar	
SERVICE CAPACITIES					
Engine oil	8 l		8 l	8 l	
Transmission oil	20.8 l		20.8 l	20.8 l	
Rear axle oil	21.2 l		21.2 l	13.6 l	
Hydraulic oil	142 l		142 l	142 l	
Fuel tank	131 l		131 l	131 l	
DEF tank	13.2 l		13.2 l	13.2 l	
Coolant	24 l		24 l	24 l	
ELECTRICAL SYSTEM					
Voltage	12 V		12 V	12 V	
Battery	Single: 95 Ah 900 A or Double: 60 Ah, 600 A (each)				
Alternator	120 A		120 A	120 A	
CAB					
Certification	ROPS / FOPS		ROPS / FOPS	ROPS / FOPS	
Air Conditioning	Optional		Optional	Optional	
Storage compartments capacity	45 l including: 2 lockable, cooling box				
Speedometer	Optional		Optional	Optional	
Bluetooth radio	Optional		Optional	Optional	
NOISE					
Internal (cab)	74 dB(A)		74 dB(A)	74 dB(A)	
External	101 dB(A)		102 dB(A)	102 dB(A)	

580SV – 590SV

DIMENSIONS AND SPECIFICATIONS

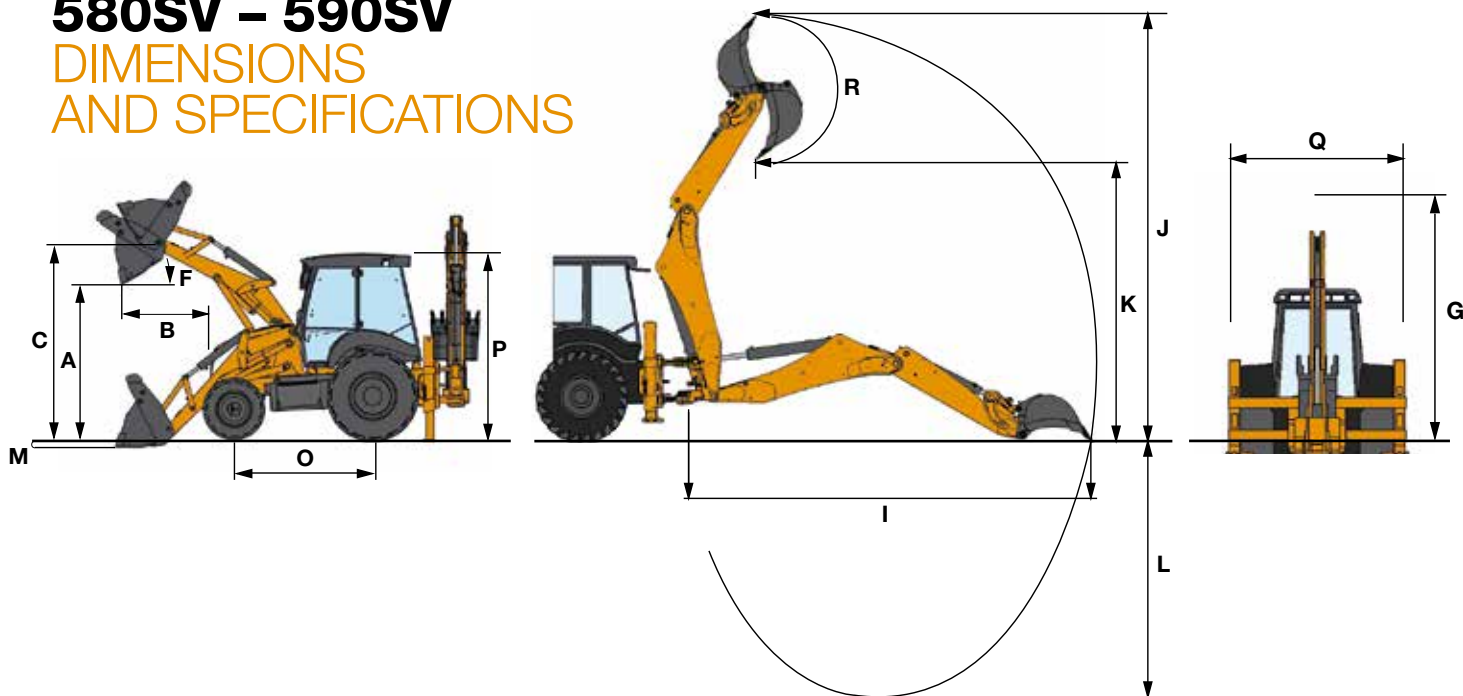

GENERAL DIMENSIONS		580SV - 590SV				580SV				
		TOOL CARRIER LOADER ARM		STRAIGHT LOADER ARM						
LOADER (4WD configuration)		Std bucket		4 x 1 bucket		Std bucket		4 x 1 bucket		
A	Maximum dump height under bucket at 45°	mm	2606	2618	2711	2726				
B	Dump Reach at full height	mm	844	825	815	785				
C	Maximum height pin	mm	3460	3458	3490	3490				
F	Dump angle	°		46		45				
M	Below ground level digging depth	mm	166	170	105	157				
	Maximum lifting capacity @ ground level	kg	5670		4731					
	Maximum lifting capacity @ max height	kg	3934	3572	3553	3290				
	Loader breakout force	daN	4910		3804					
	Bucket breakout force	daN	6338		5985					
		CASE DNA BACKHOE		IN-LINE CYLINDER BACKHOE		CASE DNA BACKHOE		IN-LINE CYLINDER BACKHOE		
BACKHOE		Std Dipper	Extendable Dipper	Std Dipper	Extendable Dipper	Std Dipper	Extendable Dipper	Std Dipper	Extendable Dipper	
	Backhoe size	ft	14 (580SV)		14 (580SV)		15 (590SV)		15 (580SV, 590SV)	
	Swinging angle	°	180							
I	Maximum reach from swing center	mm	5695	6699	5612	6286	5967	7111	5862	6991
J	Maximum operating height	mm	5802	6713	5425	6173	6043	7069	5616	6348
K	Maximum loading height	mm	3859	4752	3658	4424	4098	5124	3867	4601
L	Maximum digging depth	mm	4448	5514	4385	5627	4750	5965	4666	5881
R	Bucket rotation	°	198		203 (max amp hole)		198		203 (max amp hole)	
	Bucket breakout force	daN	5326		5971 (max force hole)		6114		5971 (max force hole)	
	Dipper breakout force	daN	3240	2375	3767	2592	3362	2420	3358	2389
OVERALL DIMENSIONS		CASE DNA BACKHOE				IN-LINE CYLINDER BACKHOE				
G	Boom height (transport position)	mm	3560				3880			
O	Wheel base	mm	2175							
P	Cab height	mm	2950							
Q	Overall width with standard loader bucket	mm	2430							
	Minimum ground clearance	mm	348							

WEIGHTS		580SV - 590SV	
	Maximum operating weight	kg	9580

OPTIONAL BUCKETS					
LOADER	Capacity (SAE ltr)	CASE DNA BACKHOE	Capacity (SAE ltr)	IN-LINE-CYLINDER BACKHOE	Capacity (SAE ltr)
Standard	1000 / 1200	300 mm backhoe trenching	80	300 mm backhoe trenching*	80
4 x 1	1000 / 1150	400 mm backhoe trenching*	110	457 mm backhoe trenching*	140
6 x 1	1000 / 1150	450 mm backhoe trenching*	120	610 mm backhoe trenching*	180
		610 mm backhoe trenching*	180	760 mm backhoe trenching*	260
		760 mm backhoe trenching	260	915 mm backhoe trenching*	320
		900 mm backhoe trenching*	300		
		1500 mm Ditch Cleaning	280		

* Standard and Heavy Duty versions

695SV

DIMENSIONS AND SPECIFICATIONS

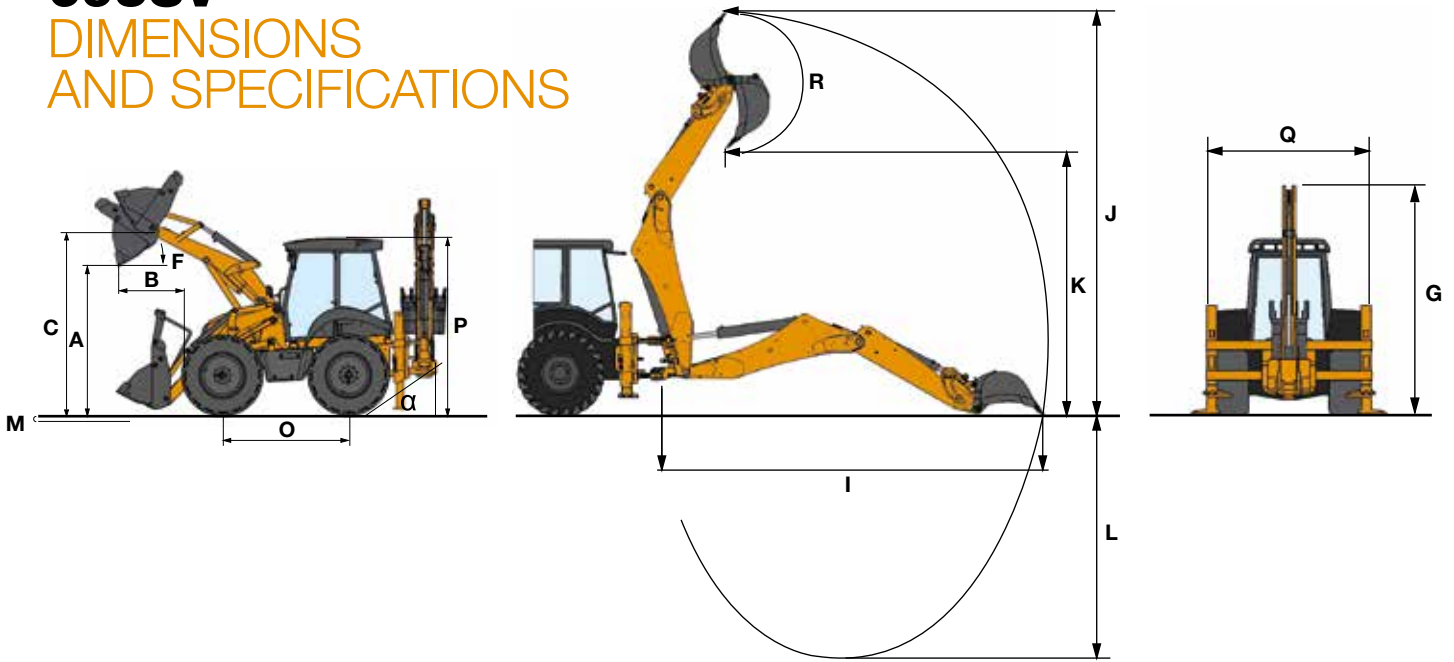

GENERAL DIMENSIONS

695SV

LOADER	TOOL CARRIER LOADER ARM				
		Std bucket	4 x 1 bucket		
A Maximum dump height under bucket at 45°	mm	2708	2718		
B Dump Reach at full height	mm	799	782		
C Maximum height pin	mm	3531	3531		
F Dump angle	°		46		
M Below ground level digging depth	mm	93	97		
Maximum lifting capacity @ ground level	kg		5350		
Maximum lifting capacity @ max height	kg	3934	3572		
Loader breakout force	daN		4350		
Bucket breakout force	daN		5240		
BACKHOE	CASE DNA BACKHOE		IN-LINE CYLINDER BACKHOE		
		Std Dipper	Extendable Dipper	Std Dipper	Extendable Dipper
Backhoe size	ft	15		15	
Swinging angle	°	180			
I Maximum reach from swing center	mm	5961	7111	5862	6991
J Maximum operating height	mm	6043	7069	5616	6348
K Maximum loading height	mm	4098	5124	3867	4601
L Maximum digging depth	mm	4750	5965	4666	5881
R Bucket rotation	°	198		203 (max amp hole)	
Bucket breakout force	daN	6114		5971 (max force hole)	
Dipper breakout force	daN	3362	2420	3358	2389
OVERALL DIMENSIONS	CASE DNA BACKHOE		IN-LINE CYLINDER BACKHOE		
G Boom height (transport position)	mm	3692		4013	
O Wheel base	mm	2220		2220	
P Cab height	mm	3060		3060	
Q Overall width with standard loader bucket	mm	2480		2480	
Ramp angle	°	34		34	

WEIGHTS

695SV

Maximum operating weight	kg	9970
--------------------------	----	------

OPTIONAL BUCKETS

LOADER	Capacity (SAE ltr)	CASE DNA BACKHOE	Capacity (SAE ltr)	IN-LINE-CYLINDER BACKHOE	Capacity (SAE ltr)
Standard	1200	300 mm backhoe trenching	80	300 mm backhoe trenching*	80
4 x 1	1150 / 1200	400 mm backhoe trenching*	110	457 mm backhoe trenching*	140
6 x 1	1150 / 1200	450 mm backhoe trenching*	120	610 mm backhoe trenching*	180
		610 mm backhoe trenching*	180	760 mm backhoe trenching*	260
		760 mm backhoe trenching	260	915 mm backhoe trenching*	320
		900 mm backhoe trenching*	300		
		1500 mm Ditch Cleaning	280		

* Standard and Heavy Duty versions

BUILDING A STRONG CASE.

Since 1842, at CASE Construction Equipment we have lived by an unwavering commitment to build practical, intuitive solutions that deliver both efficiency and productivity.

We continually strive to make it easier for our customers to implement emerging technologies and new compliance mandates.

Today, our global scale combined with our local expertise enables us to keep customers' real-world challenges at the center of our product development.

The vast CASE dealers' network is always ready to support and protect your investment and exceed your expectations, while also providing you with the ultimate ownership experience.

Our goal is to build both stronger machines-and stronger communities. At the end of the day, we do what's right for our customers and our communities so that they can count on CASE.

CNH Industrial
Deutschland GmbH
Case Baumaschinen
Benzstr. 1-3 - D-74076 Heilbronn
DEUTSCHLAND

CNH Industrial
Maquinaria Spain, S.A.
Avenida Aragón 402
28022 Madrid - ESPAÑA

CNH Industrial France, S.A.
16-18 Rue des Rochettes
91150 Morigny-Champigny
FRANCE

CNH Industrial Italia Spa
via Plava, 80
10135 Torino
ITALIA

CASE Construction Equipment
Cranes Farm Rd
Basildon - SS14 3AD
UNITED KINGDOM

NOTE: Standard and optional fittings can vary according to the demands and specific regulations of each country. The illustrations may include optional rather than standard fittings - consult your Case dealer. Furthermore, CNH Industrial reserves the right to modify machine specifications without incurring any obligation relating to such changes.

Conforms to directive 2006/42/EC

CASECE.COM
00800-2273-7373

The call is free from a land line.
Check in advance with your Mobile Operator if you will be charged. Toll free number not available from all calling areas.

